

ITEM NO.	PartNo	DESCRIPTION	QTY.
1	71583	Frame Assembly	1
2	71529	SeeMeCNC H-1 Table	1
3	71508	Bar Clamp 90 Degree	8
4	26501	Nema 17 Stepper	2
5	30318	M3-.05 x 10mm L Phillip Pan Head	8
6	30449	No 4 SAE Washer	16
7	30615	5-40 x 1" L Phillip Pan Head Screw	16
8	30166	5-40 Nylon Lock Nut Stainless Steel	16
9	71503	1/4" Dia x 13-1/2" L Linear Rail	2
10	71579	Triple Bearing Sub Assembly	2
11	71578	Double Bearing Sub Assembly	2
12	71576	Z Axis Bearing Assembly	2
13	30610	5-40 x 1/2" L Phillip Pan Head Screw	6

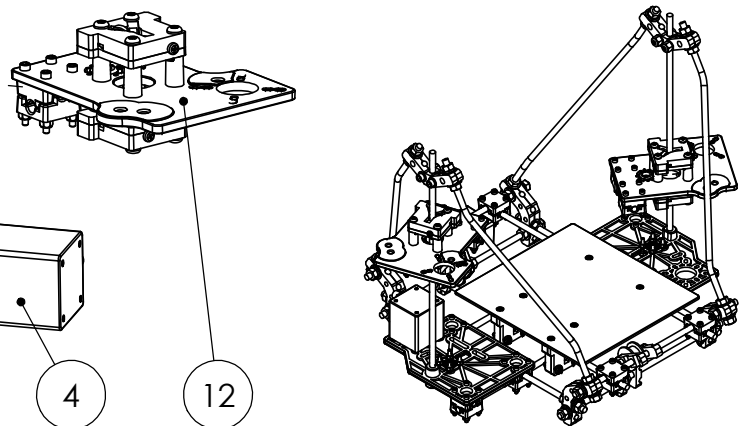

PROJECT:		
SeeMeCNC H-1		
TITLE:		
Y Axis and Z Axis Assembly to Frame		
SIZE	DWG. NO.	REV
<b>A</b>	71584	1
©2012 SeeMeCNC™		

5 4 3 2 1