

ITEM NO.	Part No	DESCRIPTION	QTY.
1	71532	X Axis Motor Mount	1
2	30156	1/4-20 Finish Nut	1
3	71508	Bar Clamp 90 Degree	4
4	30512	1/4 SAE Flat Washer	1
5	30250	#4 x 3/8" L Pan Head Sheet Metal Screw	4
6	30617	5-40 x 1-1/4 L Socket Head Cap Screw	8
7	30166	5-40 Nylon Lock Nut Stainless Steel	10
8	30272	#8 x 1" L Phillip Pan Head Sheet Metal Screw	8
9	71516	Triple Bearing Cover	2
10	71514	Triple Bearing Support	2
11	29951	1/8" Dia x 7/8" L Plastic Dowel Pin	6
12	30610	5-40 x 1/2" L Phillip Pan Head Screw	2
13	30449	No 4 SAE Washer	12
14	71505	1/8" ID x 3/8" OD x 0.156" W Plastic Bearing	6

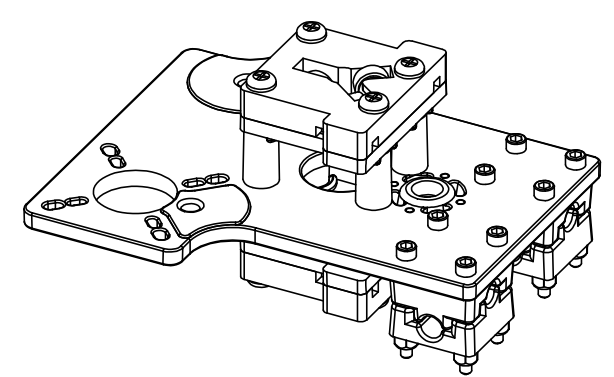

NOTE:
 1. Make two assemblies.
 2. If you have purchased metal ball bearings, replace Item 7
 3. Drill Item 9 and 10 using 5/32 drill bit.

PROJECT: SeeMeCNC H-1		
TITLE: Z Axis Bearing (X Carriage Gantry) Sub Assembly		
SIZE A	DWG. NO. 71576	REV 1
©2012 SeeMeCNC™		